

Loading (Side View - Summary) Renault Kerax 440.42 8x4 HD Sleeper Cab

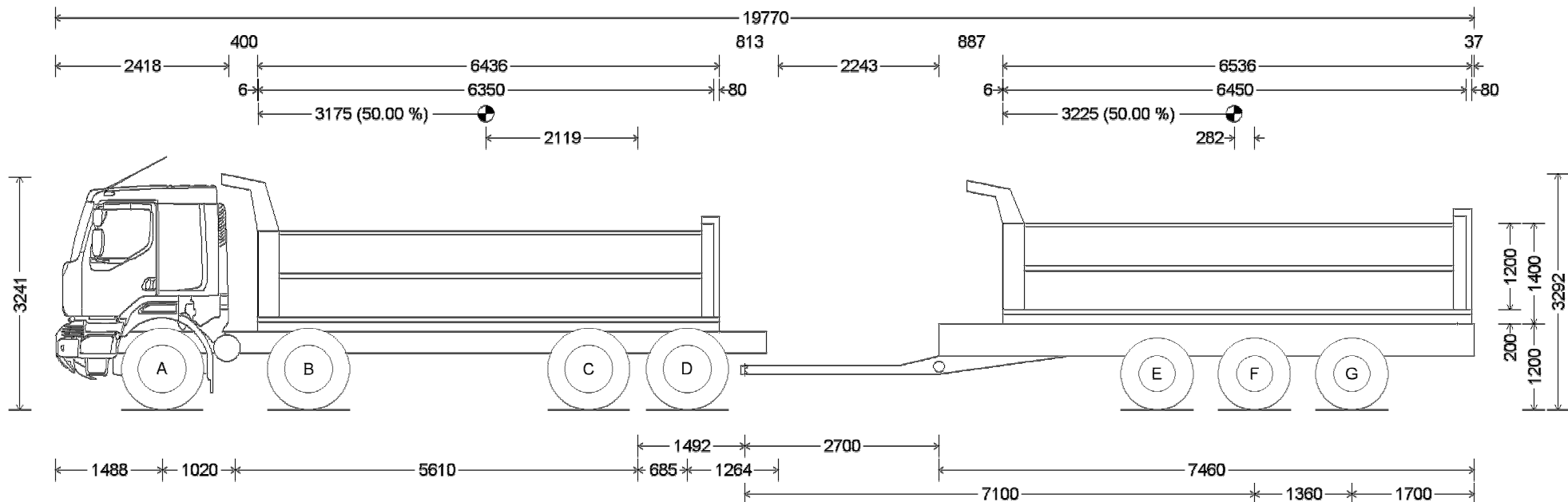

Veh. Front	Veh. Rear		Total	Tr. Rear
7,298 kg	5,287 kg	Unladen Veh.	12,585 kg	
-58 kg	275 kg	Unladen Tr.	5,533 kg	5,316 kg
7,240 kg	5,562 kg	Unladen Tot.	18,118 kg	5,316 kg
6,510 kg	10,725 kg	Payload Veh.	17,235 kg	
-185 kg	880 kg	Payload Tr.	17,507 kg	16,812 kg
6,325 kg	11,605 kg	Payload Tot.	34,742 kg	16,812 kg
13,565 kg	17,167 kg	Gross	52,860 kg	22,128 kg
15,400 kg	18,000 kg	Permissible	52,860 kg	24,000 kg
-11.92 %	-4.63 %	Overload	0.00 %	-7.80 %

Notes

- Trailer: Custom Trailer
- Accessories Added = Custom Tipper Body - 141 kg/m
- Legislation = South African Road Traffic Act

Warnings

- Vehicle wheelbase has been extended by 900 mm
- Vehicle rear overhang has been reduced by 1,325 mm
- Engineering approval is required for this wheelbase
- Left versus right mass distribution is not calculated

Prepared By :
Phone :

Prepared For :
Phone :

Date Created : 26 August 2011
Date : 26 August 2011

Disclaimer: The information in this report is an estimate only, the supplier of this report and the supplier of the software shall not be liable for consequential damage or loss arising from the reliance on the information supplied in this report.